

NF95A-270-LF

(Intel Diamondville)

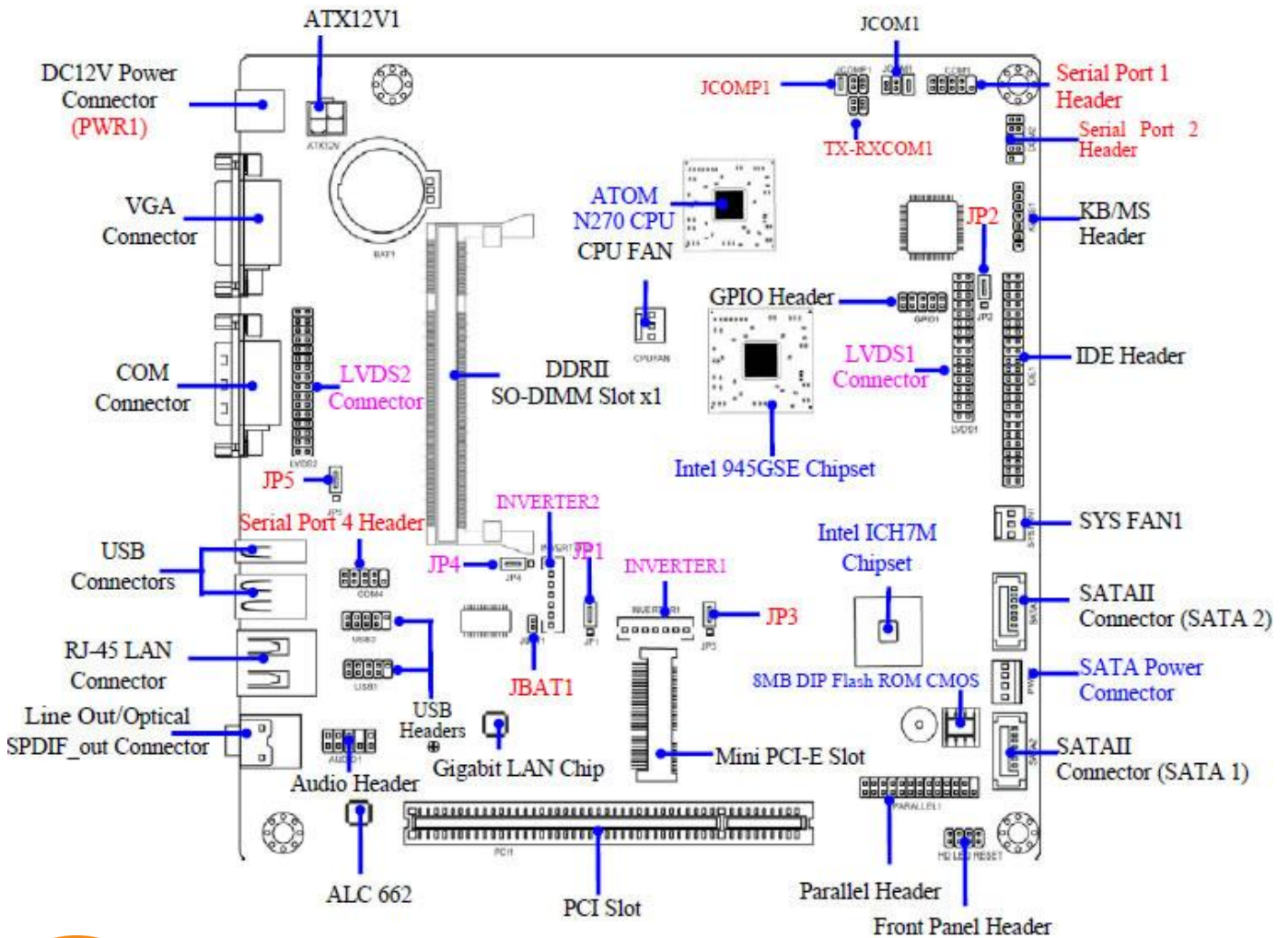

1. INTEL[®] 945GSE + ICH7M Chipset
2. Embedded INTEL[®] Atom N270 CPU (45nm, 512K Cache, 1.60 GHz, 533 MHz FSB)
3. Built-in INTEL[®] GMA 950 Graphics Core
4. Support CPU Smart FAN
5. Integrated 24-bit & 18-bit LVDS headers
6. Supports 1x Gigabit LAN
7. Supports ACPI S3 Function
8. Support Watchdog Technology
9. Mini-ITX Form Factor (17cm x 17cm)



Board Specifications

■ CPU	■ INTEL [®] Atom N270 CPU (45nm,512K Cache, 1.60 GHz, 533 MHz FSB)
■ Chipset	■ INTEL [®] 945GSE + ICH7M chipset ■ Build-in INTEL [®] GMA 950 Graphics Core (Share Memory Size: 128/224MB) ■ Front Side Bus 533MHz
■ Memory	■ 1 * SO-DIMM Sockets for un-buffered Single Channel DDR2 533/400 SDRAM up to 2 GB
■ Expansion Slots	■ 1 * PCI slot ■ 1 * MINI PCI-E
■ Storage	■ 2 * Serial ATA2 3Gb/s connectors ■ 1 * Ultra DMA 100 / 66 IDE header (44-pin mobile header)
■ Audio	■ Realtek ALC662 2-Channel HD Audio CODEC
■ Ethernet LAN	■ Realtek RTL8111DL PCI-E Gigabit Ethernet LAN
■ LVDS	■ Onboard 24-bit dual channel LVDS connector ■ Onboard 18-bit dual channel LVDS connector
■ USB	■ Embedded 7 * USB 2.0/1.1
■ Special Features	■ Intel Diamondville Platform ■ Support ACPI S3 ■ Support CPU Smart FAN ■ Support Watchdog ■ Support alternate internal power supply via an ATX12V 4-pin power connector
■ Rear Panel I / O	■ 3 * USB 2.0/1.1 ports ■ 1 * RJ-45 port ■ 1 * SPDIF OUT ■ 1 * VGA port ■ 1 * COM port ■ 1 * 12V DC in
■ Internal I / O	■ 2 * USB 2.0/1.1 headers for 4 USB 2.0 ports ■ 1 * KB/MS headers ■ NB / Chassis Fan connectors ■ 2 * 32-pin LVDS headers & 1 * GPIO header & 1 * Parallel headers ■ 3 * COM headers (COM1 for RS-422/485) ■ 1 * AUDIO header ■ 4-pin 12V ATX power connector for alternate internal power supply ■ 4-pin Power out header
■ BIOS	■ Award 8MB DIP Flash ROM
■ Form Factor	■ Mini ITX Form Factor (170mm x 170mm)
■ Functional	■ ATM, Security, Digital Signage, POS, General Application, Transportation, Thin Client
■ Certificate	■ CE, FCC, RoHS
■ Temperature	■ Operating within 0~60 centigrade ■ Storage within -20-85 centigrade

*For further information please visit the website *The Specification may be changed without further notice.



www.ibtpanelpc.com

eMail: info@ibtpanelpc.com **iBT Technologies inc.**
Toll Free: 1(866) 590-4288 Tel. (514) 832-0808 Fax. (514) 832-0128